Table of Contents

Subject	Page
MS S54	2
Objectives of the Module	2
Purpose of the System	3
System Components	4
Power Supply	6
Principle of Operation	7
Workshop Hints	8
Tools and Equipment	9
Air Management.	10
Principle of Operation.	14
Workshop Hints.	21
Tools and Equipment.	23
Fuel Management.	24
Principle of Operation.	33
Workshop Hints.	39
Tools and Equipment.	45
Ignition Management.	47
Principle of Operation.	53
Workshop Hints.	57
Tools and Equipment.	61
Emissions Management.	62
Evaporative Emissions.	62
Exhaust Emissions.	65
Principle of Operation.	70
Workshop Hints.	81
Tools and Equipment	82
Performance Controls.	84
Review Questions	88

MS S54

Model: E46 M3, E46 M3 Convertible, M roadster, M coupé

Production Date: 01/2001

Manufacturer: Siemens

Pin Connector: 134 Pins - 5 Modular Connectors

Objectives of the Module

After completing this module, you will be able to:

- Describe the Power Supply for the Fuel Injectors and Ignition Coils.
- Understand the EDR and Idle Air Actuator Operation.
- Name the Component Location of the Fuel Supply System.
- List the Inputs Required for Fuel Injector Operation.
- Describe Emission Optimized Function.
- Name the Two Types of Emissions the ECM Controls.
- Explain Why Two Sensors are used to Monitor Throttle Movement.
- Describe the Dual Input from the Accelerator Pedal.
- Locate the Diagnostic Socket.

MS S54

Purpose of the System

The MS S54 system manages the following functions:

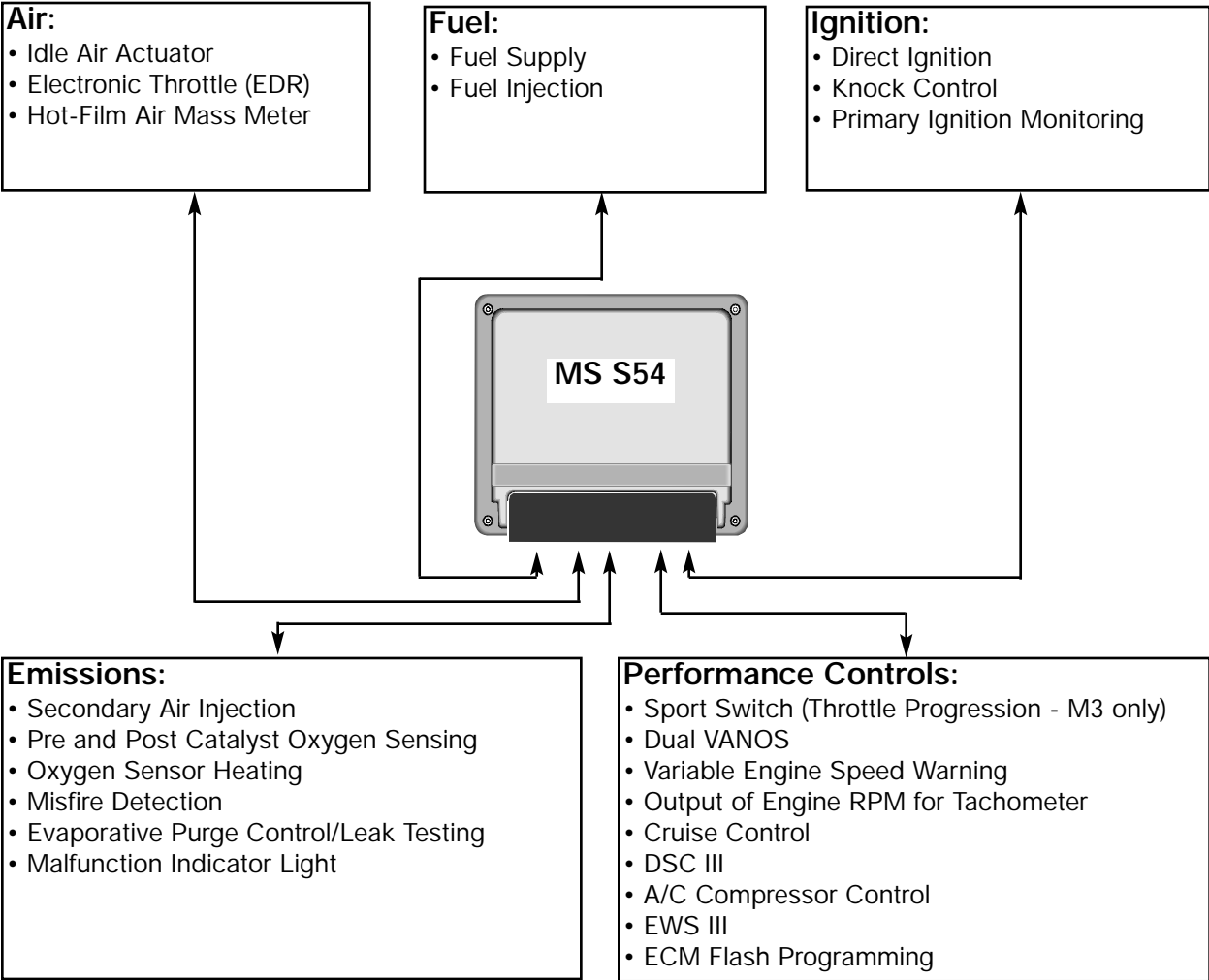

System Components

MS S54 Engine Control Module: The MS S54 ECM features a single printed circuit board with two 32-bit microprocessors.

The task of the first processor is to control:

- Engine Load
- Electronic Throttle (EDR)
- Idle actuator
- Ignition
- Knock Control

The task of the second processor is to control:

- Air/Fuel Mixture
- Emission Control
- Misfire Detection
- Evaporative Leak Detection



12410000.tiff

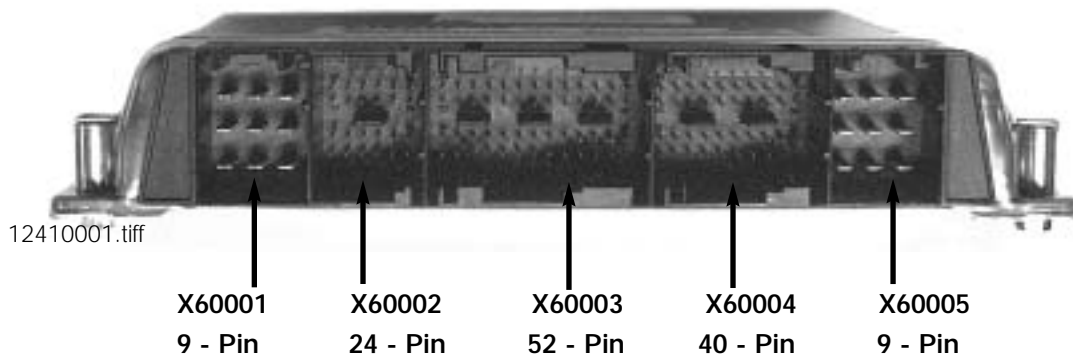

The 134 pin MS S54 Engine Control Module is manufactured by Siemens to BMW M specifications. The ECM is the SKE (standard shell construction) housing and uses 5 modular connectors. For testing, use the Universal Adapter Set (break-out box) Special Tool: # 90 88 6 121 300.

MS S54 ECM

Inputs - Processing - Outputs

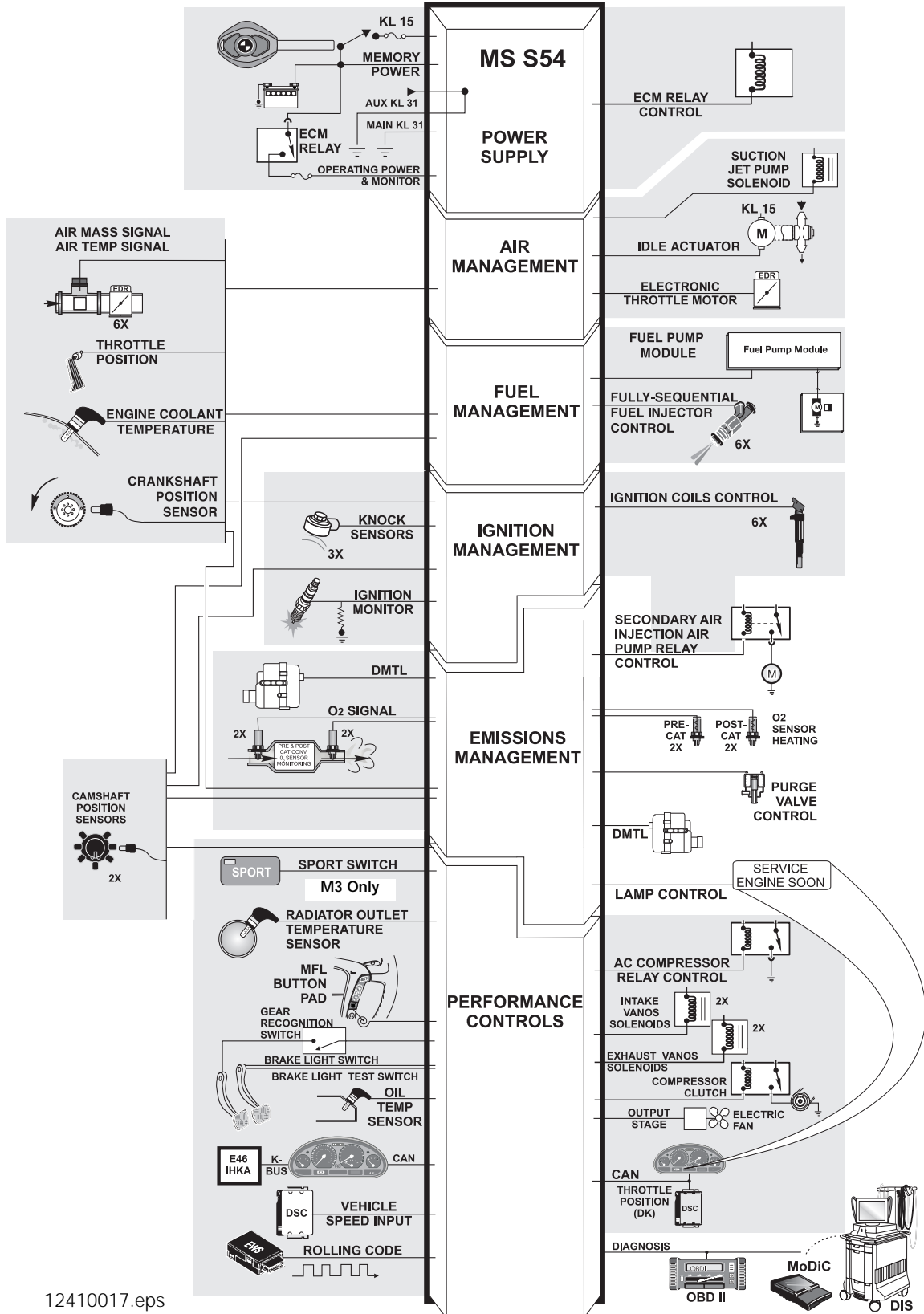

12410017.eps

Power Supply

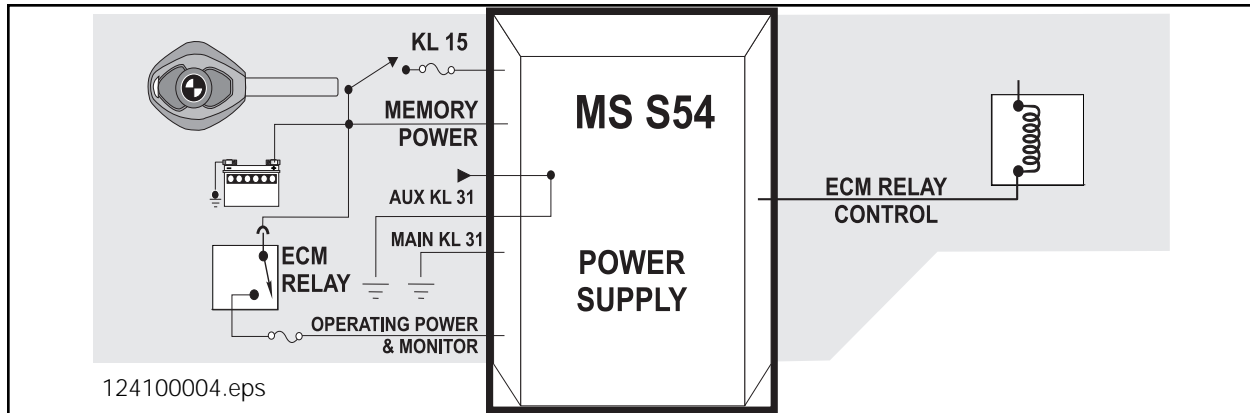

KL30 - Battery Voltage: B+ is the main supply of operating voltage to the ECM.

Power Supplies: The power supplies (KL15 and ECM Relay) are fused to the MS S54 ECM. The fuses are housed in the Engine Fuse Block located in the Electronics Box.

KL15 - Ignition Switch: When the ignition is switched "on" the ECM is informed that the engine is about to be started. KL15 (fused) supplies voltage to the Engine Control Module Relay and the Fuel Injector Relay. Switching KL15 "off" removes the ECM operating voltage.

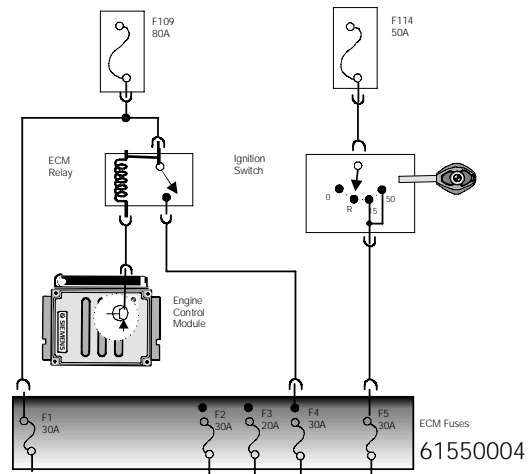

Engine Control Module Relay: The ECM Relay provides the operating voltage for:

1. ECM	6. Ignition Coils
2. Fuel Injector Relay	7. DMTL
3. Idle Air Actuator	8. Camshaft Sensor
4. Evaporative Emission Valve	9. Hot Film Air Mass
5. Fuel Pump Relay	10. Oxygen Sensor Heaters

Ground: Multiple ground paths are necessary to complete current flow through the ECM. The ECM ground pin numbers are:

Connector X60001	Connector X60004	Connector X60005
Pin 4 - Ground for ECM	Pin 5 - Ground for ECM	Pin 5 - Ground for ECM
Pin 5 - Ground for ECM		
Pin 6 - Ground for ECM		

Principle of Operation

Battery Voltage is monitored by the ECM for fluctuations. It will adjust the output functions to compensate for a lower (6v) and higher (14v) voltage value. For example, the ECM will:

- Modify pulse width duration of fuel injection.
- Modify dwell time of ignition.

When **KL15** is switched "on" the ECM is ready for engine management. The ECM will activate ground to energize the Engine Control Module Relay. The Engine Control Module Relay supplies operating voltage to the ECM and the previously mentioned operating components. Five seconds after the ignition is switched on and the voltage at the KL15 input is >9 volts, the ECM compares the voltage to the ECM Relay supplied voltage. If the voltage difference between the two terminals is greater than 3 volts, a fault code will be set.

When **KL15** is switched "off" the ECM operating voltage is removed. The ECM will maintain a ground to the Engine Control Module Relay for a few seconds to maintain ignition coil activation (Emission Optimized - introduced in 2000 MY).

Ground is required to complete the current path through the ECM. The ECM also:

- Internally links a constant ground (1) to the engine sensors.
- Switches ground (2) to activate components.

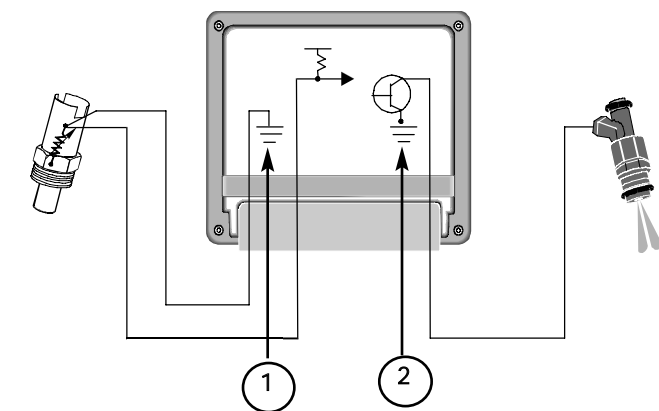

61420002.eps

Workshop Hints

Power Supply - Testing

Inadequate power and ground supply can result in:

1.	No Start
2.	Hard Starting (Long Crank Times)
3.	Inaccurate Diagnostic Status or ECM (Not Found)
4.	Intermittent / Constant "Malfunction Indicator Light"
5.	Intermittent/Constant Driveability Problems

Electronics Box - ECM and Fuses



12410003.tiff

Power supply including fuses should be tested for:

1.	Visual (1) Blown Fuse
2.	Available Voltage (2)
3.	Voltage Drop (Dynamic Resistance) (2)
4.	Resistance of Cables and Wires (2)

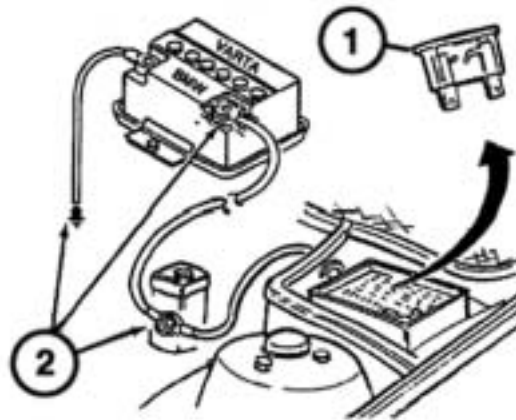

12550006.bmp

The ignition (KL15) must be switched off when removing or installing the ECM connector to prevent voltage spikes (arcing) that can damage the Control Module!



The Engine Control Module Relay (located in the Electronics Box) should be tested for:

1.	Battery Voltage and Switched Ground (1)
2.	Resistance (1)
3.	Battery Voltage and Voltage Drop (2)

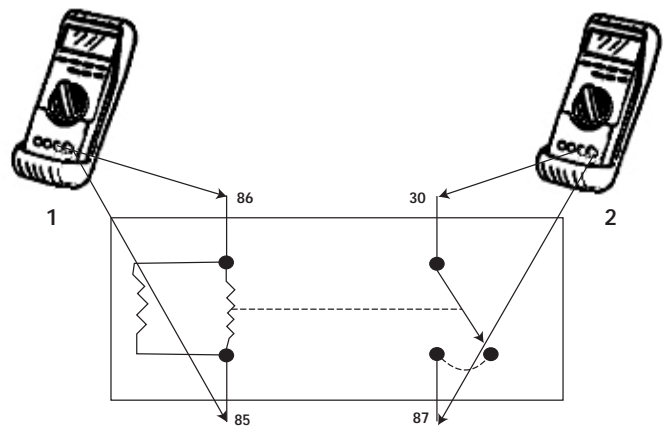

12410005.eps

Tools and Equipment

Power Supply

When testing power supply to an ECM, the DISplus/MoDIC multimeter function as well as a reputable hand held multimeter can be used.

It is best to make the checks at the ECM connection, this method includes testing the wiring harness.

The correct Universal Adapter for the MS S54 application should be used (#90 88 6 121 300). This will ensure the pin connectors and the harness will not be damaged.

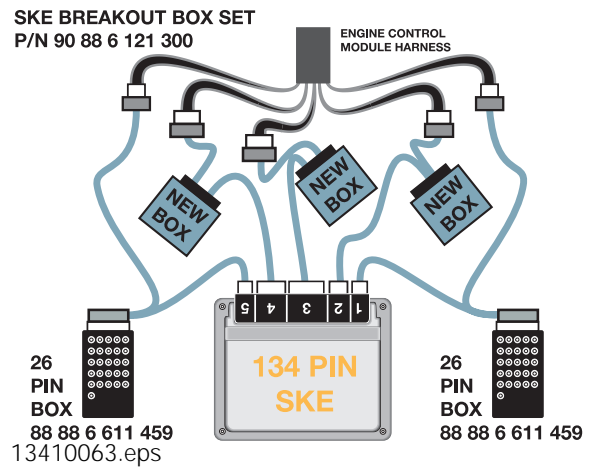

When installing the Universal Adapter to the ECM (located in the Electronics Box in engine compartment), ***make sure the ignition is switched off.***



12410002.tiff

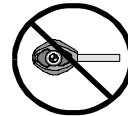

The Engine Control Module **Relay** should be tested using the relay test kit (P/N 88 88 6 613 010) shown on the right.

This kit allows testing of relays from a remote position.

Always consult the ETM for proper relay connections.

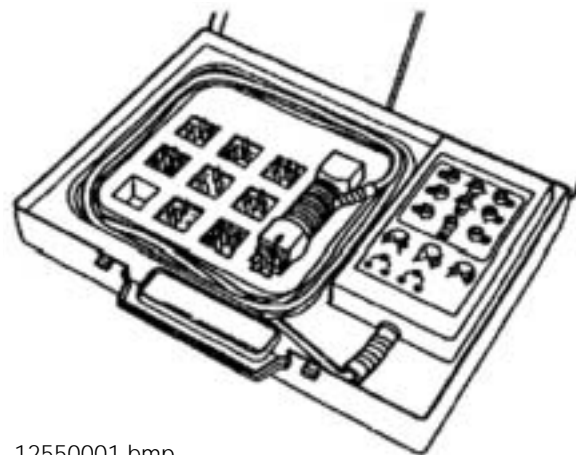

12550001.bmp

Air Management

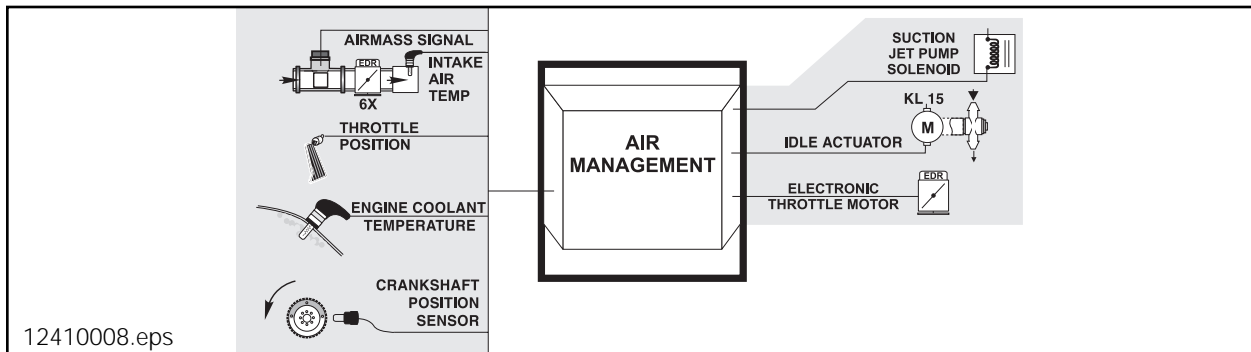

Throttle Valves: The mechanical throttle valves regulate the intake air flow and are operated by an Electronic Throttle Actuator (1 EDR).

The throttle valves are an assembly of six individual throttle housings linked by a common shaft. The throttle opening depends on engine rpm and load (1000 kg/h maximum air flow).



11410057.tiff

Refer to the Repair Instructions for throttle adjustments.

Accelerator Pedal Position (PWG): The accelerator pedal module (E46 M3) provides two variable voltage signals to the ECM that represents accelerator pedal position and rate of movement. The ECM will activate the EDR and Idle Air actuator based on the request.

Dual Hall sensors are integral in the accelerator pedal module. The ECM compares the two values for plausibility.

The M roadster and M coupe use a remote mounted PWG. This type uses twin potentiometers to produce the same input signals (voltage) as the Hall sensors.

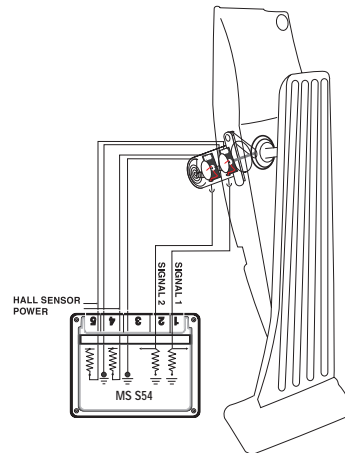

13410065.eps



The ECM provides voltage (5v) and ground for the Hall sensors. As the accelerator pedal is moved from rest to full throttle, the sensors produce a variable voltage signal.

Hall sensor 1(request) = 0.5 to 4.5 volts
 Hall sensor 2 (plausibility) = 0.5 to 2.0 volts

If the signals are not plausible, the ECM will use the lower of the two signals as the request input. The throttle response will be slower and the maximum throttle response will be reduced.

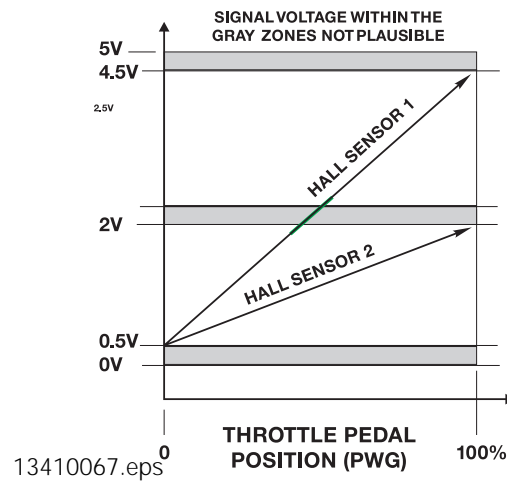

The potentiometer PWG produces the same voltage signals to the ECM.

Electronic Throttle Actuator (EDR): The EDR is specifically designed for the S54 engine. This allows one actuator to operate all six throttles via a common linkage.

The ECM provides the operating voltage and ground to the EDR for opening and closing the throttles. The ECM monitors a feedback potentiometer located on the actuator shaft (arrow) for actuator position/plausibility (closed 4.5v - full open 0.5v).



There is a return spring fitted to the actuator lever end that assists in closing the throttles.

Throttle Valve Position: A potentiometer is fitted to the end of the throttle shaft (arrow) that allows the ECM to monitor throttle position.

This signal is used by the ECM for a position/plausibility check (closed 0.5v - full open 4.5v).

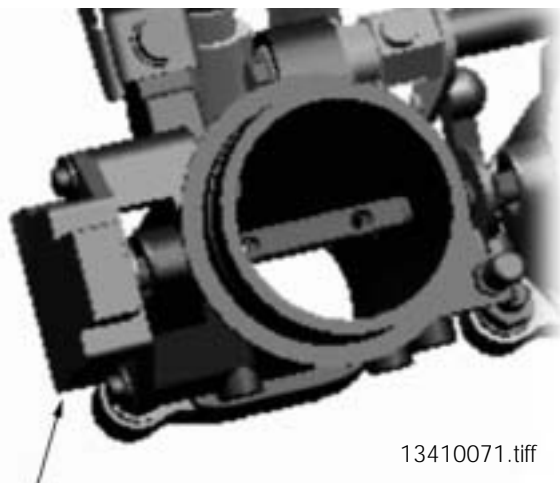

Idle Air Actuator: The Idle Air Actuator is a two-coil rotary actuator (ZWD5). The S54 features a second air supply system that functions independent of the throttle valve control system (EDR). This actuator regulates air by-passing the throttle valves to control low engine speed.

The valve is supplied with operating voltage from the ECM Relay. The ECM is equipped with two final stage transistors which will alternate positioning of the actuator. The final stages are "pulsed" simultaneously by the ECM which provides ground paths for the actuator. The duty cycle of each circuit is varied to achieve the required idle RPM.

The valve (2) regulates air flow through an external air distribution pipe to the individual throttle housings. The inducted air is shared between the idle actuator and throttle valves depending on the engine load. The maximum air flow of the idle air actuator (80 kg/h) permits emergency operation of the vehicle (limp-home mode).

Hot-Film Air Mass Meter (HFM): The air volume input signal is produced electronically by the HFM which uses a heated metal film in the air flow stream. The HFM housing is integral with the air filter upper housing (one-piece).

The ECM Relay provides the operating voltage. As air flows through the HFM, the film is cooled changing the resistance which affects current flow (voltage drop) through the circuit as the resistance changes. The ECM monitors this change regulating the amount of fuel injected.

If these components/circuits are defective, a fault code will be set and the "Malfunction Indicator Light" will be illuminated when the OBD II criteria is achieved.

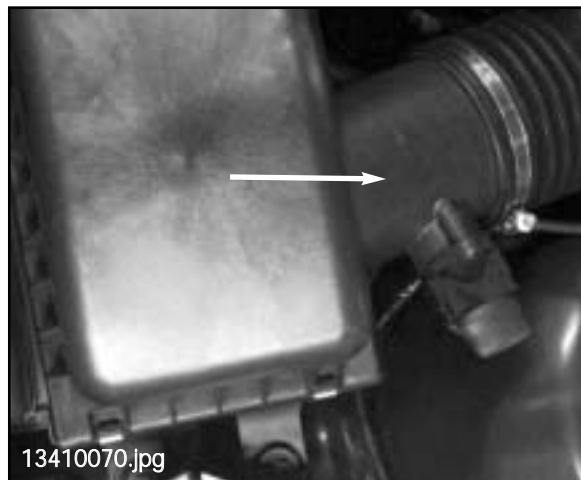
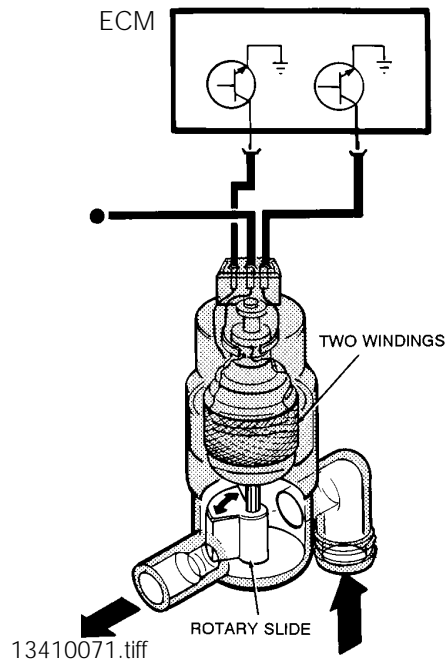

Air Temperature Signal: The HFM contains an integral air temperature sensor. This is a Negative Temperature Coefficient (NTC) type sensor. This signal is needed by the ECM to correct the air volume input for changes in the intake air temperature (air density) affecting the amount of fuel injected, ignition timing *and Secondary Air Injection activation*.

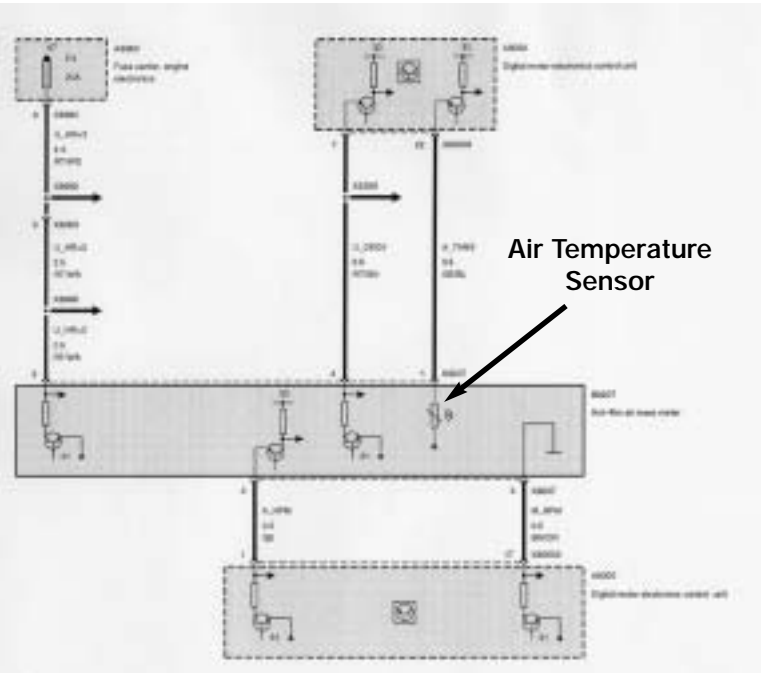

12410001.bmp

The ECM provides the power supply to this component. The sensor decreases in resistance as the temperature rises and vice versa. The ECM monitors an applied voltage to the sensor that will vary as air temperature changes the resistance value.

If this input is defective, a fault code will be set and the "Malfunction Indicator Light" will be illuminated when the OBD II criteria is achieved. The ECM will operate the engine using the Engine Coolant Sensor input as a back up.

Suction Jet Pump: The ECM regulates the Suction Jet Pump (1) to provide sufficient vacuum for the brake booster under all operating conditions. The ECM controls the Suction Jet Pump Solenoid (2) to allow vacuum flow through.

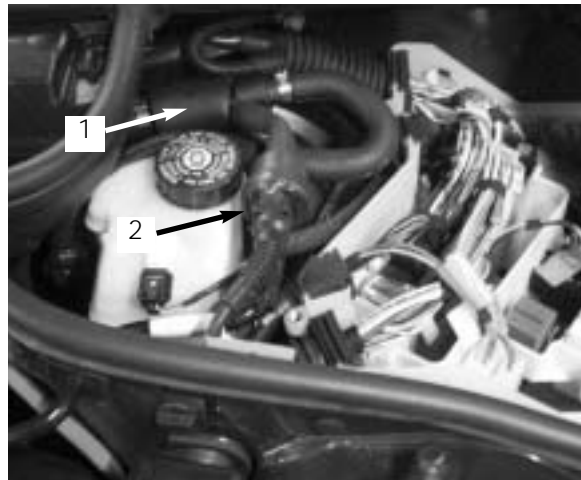

Additional vacuum compensation is applied to the brake booster when the circuit is "deactivated" (solenoid sprung open).

Vacuum enhancement is limited to the brake booster when the control circuit is "activated" (solenoid powered closed).

Principle of Operation

Air flow into the engine is regulated by the Throttle Valves and/or the Idle Air Actuator. Both of these air “passages” are necessary for smooth engine operation from idle to full load. On the MS S54 system, the Throttle Valve and the Idle Air Actuator are **electrically controlled**. All of the ECM monitoring, processing and output functions are a result of regulated air flow.

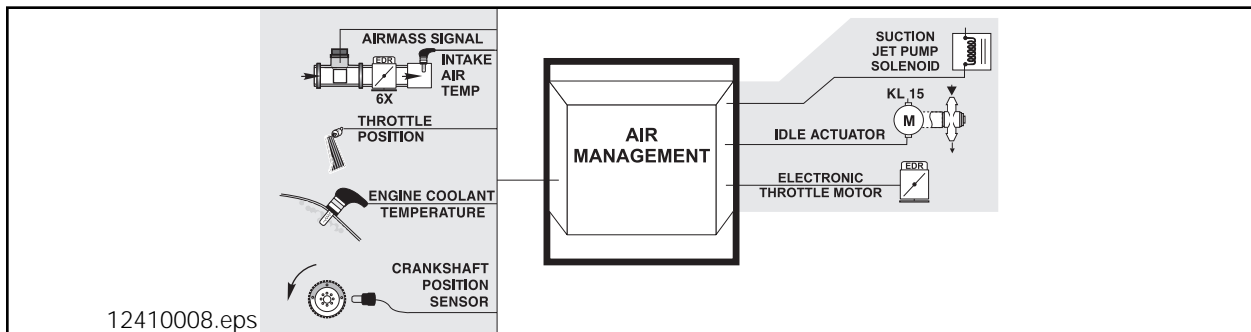

The Accelerator Pedal Position (M3 PWG) is monitored by the ECM for pedal angle position and rate of movement. As the accelerator is moved, a rising voltage signal from the Hall sensors requests acceleration and at what rate. The ECM will increase the volume of fuel injected into the engine, advance the ignition timing and open the Throttle Valves and/or Idle Air Actuator. The “full throttle” position indicates maximum acceleration to the ECM, and in addition to the functions just mentioned, this will have an effect on the air conditioning compressor (covered in Performance Controls).

As the accelerator pedal is released (integral springs), a decrease in voltage signals the ECM to activate fuel shut off if the rpm is above idle speed (coasting). The Throttle Valves will be closed and Idle Air Actuator Valve will open to maintain idle speed.

The ECM monitors the engine idle speed in addition to the accelerator pedal position and throttle position voltage. If the voltage values have changed (mechanical wear of throttle plates or linkage), the ECM will adjust the Idle Air Actuator to maintain the correct idle speed.

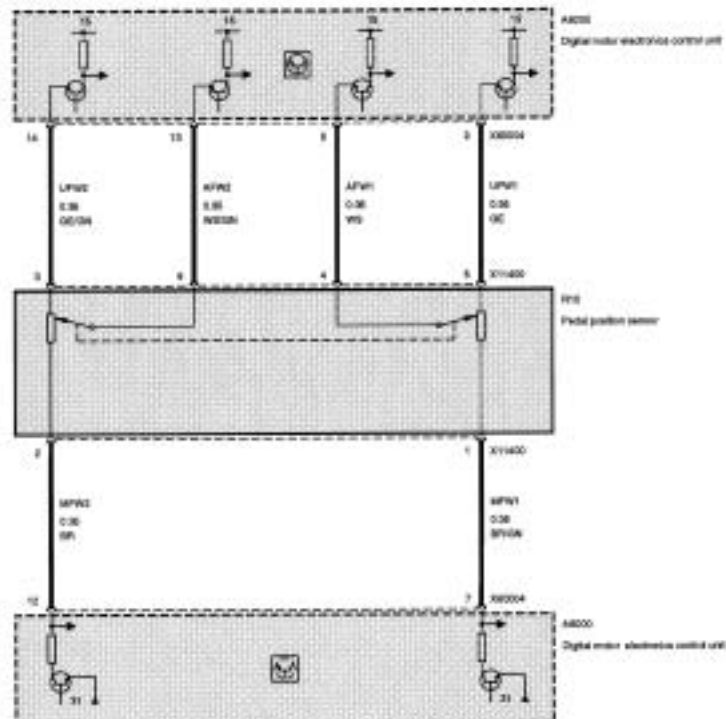

The pedal position sensor consists of two separate Hall sensors with different voltage characteristics and independent ground and voltage supply. Sensing of the accelerator pedal position is redundant. The pedal position sensor is monitored by checking each individual sensor channel and comparing the two pedal values. Monitoring is active as soon as the sensors receive their voltage supply (KL15). The ECM decides what operating mode the pedal position sensor is to assume.

Mode 0 = Pedal position sensor fully operable

Mode 1 = Failure of one pedal position sensor (maximum engine speed is limited)

Mode 2 = Failure of both pedal position sensors (engine speed limited to 1500 rpm)

The potentiometers/Hall sensors are non-adjustable because the ECM “learns” the throttle angle voltage at idle speed. If the throttle housing/accelerator pedal module is replaced, the **ADAPTATIONS MUST BE CLEARED and ADAPTATION PROCEDURE MUST BE PERFORMED** using the DISplus/MoDIC. **If this is not performed, the vehicle will not start, or run in “fail-safe” mode.**

If this input is defective, a fault code will be stored and the “Malfunction Indicator and/or EML” Light will be illuminated. Limited engine operation will be possible.

The Idle Air Actuator is controlled by the ECM modulating the ground signals (PWM at 100 Hz) to the valve. By varying the duty cycle applied to the windings, the valve can be progressively opened, or held steady to maintain the idle speed. The ECM controls the Idle Air Actuator to supply the necessary air to maintain idle speed. When acceleration is requested and the engine load is low (<15%), the actuator will also supply the required air.

There are additional factors that influence the ECM in regulating idle speed:

- The RPM sensor input allows the ECM to monitor engine speed because of loads that cause idle fluctuations due to drag on the engine: power steering, thick oil (frictional forces), etc.
- Cold engine temperature (coolant NTC) provides higher idle speed to raise temperature sooner.
- Vehicle speed informs ECM when the vehicle is stationary and requires idle maintenance.
- A/C on request from the climate control system (arming the ECM) and compressor engage (stabilize idle speed) acknowledgment.

The Electronic Throttle Actuator (EDR) is operated by the ECM for opening and closing based on the accelerator pedal position, DSC intervention and cruise control functions. For exclusive control, the ECM supplies the voltage and ground for operation. The system requires approx. 110 milliseconds in order to fully open the closed throttle valves.

When the EDR is operated, the ECM monitors a feedback potentiometer located on the actuator shaft for position/plausibility. As the EDR opens the Throttle Valves to accelerate the engine, the position is also monitored by a feedback potentiometer located on the end of the throttle shaft on the number 1 throttle housing. These two sensors operate inversely (voltage values) with throttle actuation.

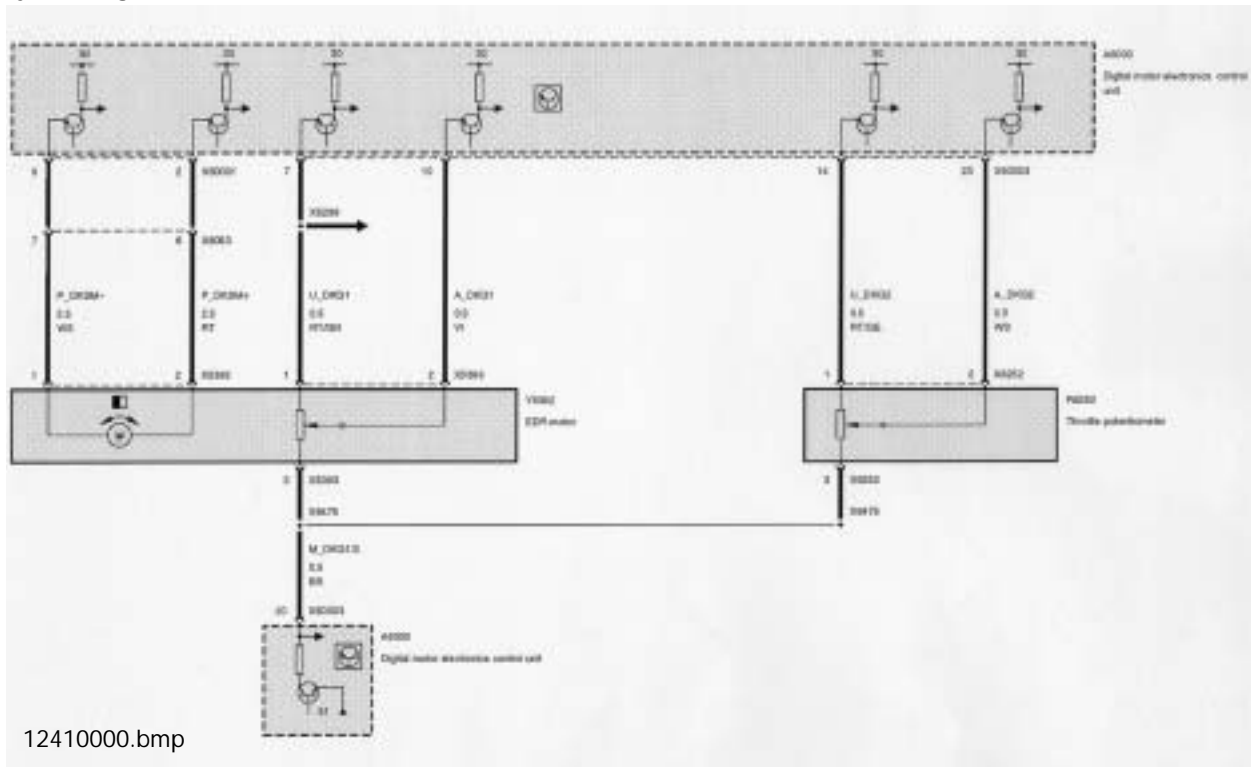

The EDR actuator will “open” the throttle valves for acceleration when the engine load is >15%. There is a transition during acceleration when the Idle Air Actuator will also be open providing additional air for initial acceleration torque.

With the Idle Actuator System and Electronic Throttle Control (EDR), the S54 is equipped with two independent air systems. The ECM is therefore capable of dividing the air volume of the engine between the idle actuator and/or throttle valves corresponding to the load status.

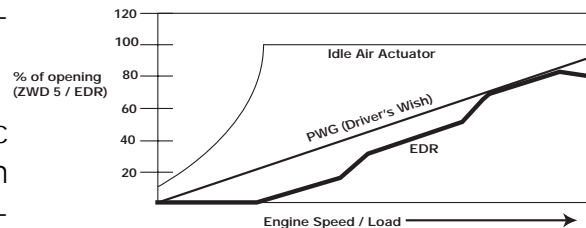

00410010.eps

Pre-drive Check

The pre-drive check has following tasks:

- Zero point adaptation of the throttle potentiometers.
- Checking freedom of movement of the throttle valves and electronic accelerator pedal control circuit.
- Checking the safety cutout and the return springs of the electronic accelerator pedal and throttle valves.

This check is conducted every time KL15 is activated. The full load adaptation stop is learned in a new ECM the first time KL15 is recognized.

The pre-drive check is conducted in 3 phases:

- Phase 1: The throttle valves are closed by the EDR actuator. The position of the throttle potentiometer on the EDR is determined.
- Phase 2: The throttle valves are opened 3% by the EDR actuator. The position of the throttle potentiometer on the throttle valve shaft is determined.
- Phase 3: The throttle valves are opened by approx. 20%. The EDR actuator is switched off. The throttle valves are closed by spring force (a mechanical clicking sound can be heard while the throttle valves are closing).

Post Drive Check

- Post Drive Check: 10 seconds after KL15 is switched "OFF" the EDR actuator is opened 102% in order to carry out renewed full load adaptation. Adaptation during the post drive check is only carried out when the engine is turned off before reaching the operating temperature.

EDR Safety Concept - Emergency Running Programs

The safety concept of the throttle valve control system achieves a slow transition to an emergency running (limp-home) program that can still be managed by the driver.

A basic differentiation is made between PWG emergency operation with a PWG sensor and PWG emergency operation without a PWG sensor. There is a total of 4 emergency operation (limp-home) program stages.

In the event of a PWG sensor failing, the system switches to a PWG emergency operation characteristic curve with lower setpoints. "Engine Emergency Program" is indicated to the driver by the EML warning lamp in the instrument cluster.

Stage 1 (Emergency Operation with a Throttle Position Sensor)

The emergency program stage 1 includes limiting the torque and the EDR setpoint. Based on the current engine torque, the maximum torque is limited in the emergency operation stage. The EDR actuator is limited by reducing the pulse duty factor. The plausibility of the throttle position sensors are checked based on the load signal from the hot-film air mass meter. The measured air mass must not exceed a defined limit. This limit is above the value that can be achieved with the idle air actuator.

Stage 2 (Emergency Operation via Idle Air Actuator)

The transition to emergency program stage 2 greatly depends on the type of fault. For example, if there is a defect in EDR actuator operation, the throttle valves are sprung closed without ECM influence.

In the event of implausible signals from the throttle position Hall sensors 1 and 2, immediate deactivation of the EDR actuator may be necessary under certain circumstances.

In cases where feedback of the actual position is still available and the set position can still be controlled, the ECM closes the throttle valves. The EDR actuator is then switched off and engine speed and road speed limitation activated.

Stage 3 (Emergency Operation with Open Throttle Valves)

The stage 3 emergency operation program is activated when the actual throttle position exceeds the set throttle position for a defined period of time despite power being applied to the EDR actuator, the throttle valves cannot be closed. The ECM reduces the amount of fuel injected (fade out) and retards the ignition timing to limit engine torque. If it is necessary to further reduce the torque, individual fuel injectors are deactivated one cylinder at the time.

Stage 4 (Emergency Operation with Internal ECM Fault)

The stage 4 emergency operation program is always activated when an internal ECM fault is detected. In this case, the characteristics of the throttle valve control (EDR) are not predictable, therefore the ECM reduces the amount of fuel injected (fade out) and retards the ignition timing to limit engine torque. If it is necessary to further reduce the torque, individual fuel injectors are deactivated one cylinder at the time.

Emergency Operation Functions

Engine torque limitation In the emergency programs stage 1 - 4 is restricted to a value specified by the emergency operation (limp-home) program.

Stage	Engine Speed RPM	Road Speed km/h	Torque Nm
1	7600 rpm	240 km/h	320 Nm
2	4000 rpm	80 Km/H	250 Nm
3	2750 rpm	50 km/h	200 Nm
4	2750 rpm	50 km/h	200 Nm

00410009.eps

In the relevant emergency programs, the MS S54 limits the engine characteristics to the values indicated in the table. In emergency programs 3 and 4, in addition to the engine emergency program being indicated in the instrument cluster (EML), ***all warning elements in the tachometer are activated.***

The Hot-Film Air Mass Meter (HFM) varies voltage monitored by the ECM representing the measured amount of intake air volume. This input is used by the ECM to determine the amount of fuel to be injected.

The heated surface of the hot-film in the intake air stream is regulated by the ECM to a constant temperature of 180° above ambient air temperature. The incoming air cools the film and the ECM monitors the changing resistance which affects current flow through the circuit. The hot-film does not require a “clean burn”, it is self cleaning due to the high operating temperature for normal operation.

If this input is defective, a fault code will be set and the “Malfunction Indicator Light” will illuminate when the OBD II criteria is achieved. The ECM will maintain engine operation based on the Throttle Position Sensors and Crankshaft Position/Engine Speed Sensor.

The Air Temperature signal allows the ECM to make a calculation of air density. The varying voltage input from the NTC sensor indicates the larger proportion of oxygen found in cold air, as compared to less oxygen found in warmer air. The ECM will adjust the amount of injected fuel because the quality of combustion depends on oxygen sensing ratio.

The ignition timing is also affected by air temperature. If the intake air is hot the ECM retards the base ignition timing to reduce the risk of detonation. If the intake air is cooler, the base ignition timing will be advanced. The ECM uses this input as a determining factor for Secondary Air Injection activation (covered in the Emissions section).

If this input is defective, a fault code will be set and the “Malfunction Indicator Light” will illuminate when the OBD II criteria is achieved. The ECM will maintain engine operation based on the HFM and Engine Coolant Temperature sensor.

The Suction Jet Pump is regulated by the ECM to provide sufficient vacuum for the brake booster under all operating conditions. The ECM controls the Suction Jet Pump Solenoid to allow vacuum flow through.

The additional vacuum compensation is activated by the ECM when the idle air actuator is regulated for:

- A/C compressor “on”
- Vehicle in gear and the clutch is released (driving under load)
- Engine in warm-up phase <70° C

Additional vacuum compensation is applied to the brake booster when the circuit is “deactivated” (Solenoid sprung open). Vacuum enhancement is limited to the brake booster when the control circuit is “activated” (Solenoid powered closed).

Workshop Hints

Air Management

Unmetered air leaks can be misleading when diagnosing faults causing "Malfunction Indicator Light"/driveability complaints. Refer to S.I. # 11 03 92 (3500) for testing intake vacuum leaks.

Crankcase Ventilation System

A fault in this system can often "mislead" diagnosis. This type of fault can produce:

- Mixture/misfire defect codes
- Whistling noises
- Performance/driveability complaints

Please refer to the following Service Information Bulletins for details on the *Crankcase Ventilation System*:

- Crankcase Ventilation System Check S.I. #11 05 98

Throttle Position Sensors - Testing

The Throttle Position Sensors (potentiometers) can be tested with the following methods:

- DISplus Status Page (approx. 0.5v to 4.5v)
- DISplus Oscilloscope - Select from the Preset Measurements which requires taking the measurement with the ECM and Universal Adapter connected to the circuit (as shown on the right).
- Resistance check of the entire circuit, using the Universal Adapter with the ECM disconnected.

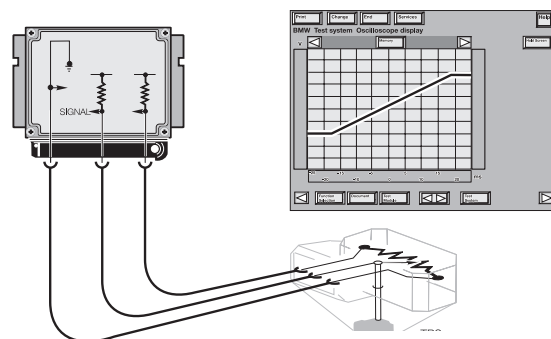

13410008.eps

Idle Air Actuator - Testing

- The Idle Air Actuator and idle air circuit (passage ways) should be checked for physical obstructions.
- The resistance of the valve winding should be checked.
- The ECM output and Idle Speed Control Valve operation can be tested by "Component Activation" on the DISplus/ModIC.
- The Pulse Width Modulated ground output from the ECM can be tested using the DISplus/ModIC Oscilloscope.
- Consult Technical Data for specified idle speed.

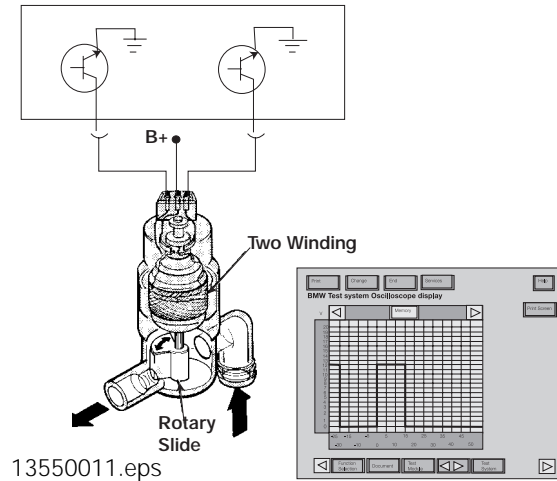

Tools and Equipment

The DISplus/MoDIC as well as a reputable hand held multimeter can be used when testing inputs/components.

It is best to make the checks at the ECM connection, this method includes testing the wiring harness.

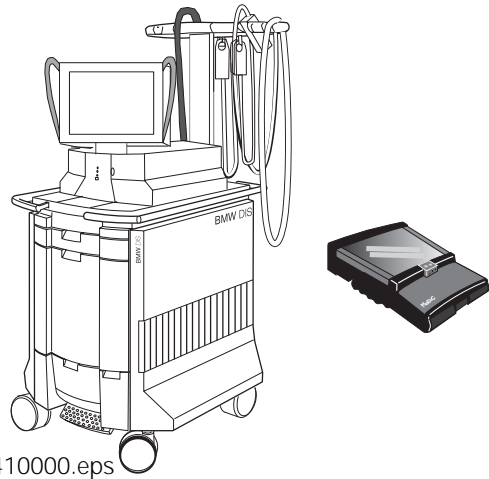

The correct Universal Adapter for the MS S54 application should be used (#90 88 6 121 300). This will ensure the pin connectors and the harness will not be damaged.

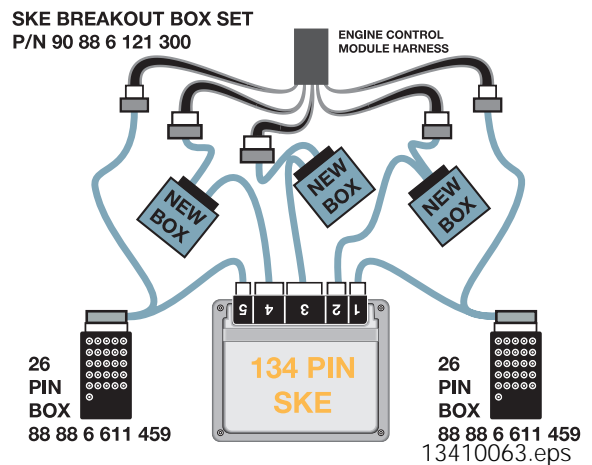

When installing the Universal Adapter to the ECM (located in the Electronics Box in the engine compartment), **make sure the ignition is switched off.**



The Slack Tube Manometer Test Tool (#99 00 0 001 410) should be used to troubleshoot crankcase ventilation valves.

